



SALES HEAD OFFICE

Tel:86-757-86696312

Indian Office: T/F: 0091-2822240379  
Add: 32 Rachana Society, Sobheshwar Road, Morbi, India.

Hebei Office: T/F: 0311-84031245

Shandong Office: T:0533-7904366, F:0533-7904368

Linyi Office: T/F:0539-8261449

Jiangxi Office: T/F: 0795-5603086

Qingyuan Office: T/F: 0763-3122538  
Enping Office: T/F: 0750-7689910

Jinli Office: T/F: 0758-8596033

Sichuan Office: T: 0833-5830058 F:0833-5830055

GUANGDONG BOFFIN MECHANICAL & ELECTRICAL CO.,LTD

地址: 广东省肇庆市高新区工业大街 6 号  
Add:No.6 of Industry street, High-tech Park, Zhaoqing City, Guangdong, China.  
Tel:+86-0758-6639926 6639925, FAX: +86-0758-6639927  
E-mail:wintopforever@vip.163.com  
www.foshan-boffin.com



# FEEDING SYSTEM





# ENTERPRISE

## PROFILE:

Guangdong Boffin Mechanical and Eletrical Co., Ltd. has more than 300 users in the world. Professional for ceramics factories tailored technology, such as Magical Grinding System, Omni-directional Feeding System, Easy-color System (full-body tile), and Powder Dry process technology.

## CORPORATE CULTURE

Enterprise goal: To be extensive and profound, to achieve mutual brilliance  
 Business philosophy: Innovate your creativity  
 Service tenet: Aiming at exceeding customers' requirements  
 Team spirit: Uncompromising responsibility and dedication.

## MANAGEMENT STYLE

Quality—Enterprise brand, human-oriented quality  
 Innovation—Pioneering and taking the lead  
 Talent—Human orientation, respect for talents  
 Responsibility—Taking responsibility courageously, making contributions enthusiastically  
 Harmony—Harmonious cooperation, harmonious development



Picture comparison of marble tile and normal tile

Normal tile picture



Marble tile picture



**Solution:**

In order to treat with the veins of tile body, BOFFIN company developed marble tile feeding system to make the tile body same as the surface design to reproduce the reality of natural marble. It is suitable for extending groove, chamfering, cutting of tile to meet the requirement of different decoration to show the natural marble style.

**Apply to:**

Tile body of glaze tile, such as rustic tile, wall tiles, GVT, marble tiles, ultra flat glazed tiles, PGVT, base powder of dual marble tiles.

**Product feature**

TILE 1, SIDE FACE



TILE 2, SIDE FACE



PART FEATURE OF TILE 1



PART FEATURE OF TILE 2



**Decoration application of marble tile**



Square Groove



Chamfering Curve



Downward Triangle



The Corner

TECHNOLOGY PROCESS

■ ;

;

o

### BOFFIN DRY COLOR SYSTEM

**ADVANTAGES:**

**Switch to different product easily , shrink the time.**  
Switch to needed product in any time, without limiting by production capacity

**Does not need cleaning , save labor cost.**  
Don't need to clean the slip pool while switching to different product. Consumedly save manpower. Lower the process cost.

**Save pigment, lower the cost.**  
No any waste of base powder and pigment while switching of production. More cleaning and environmental protect.

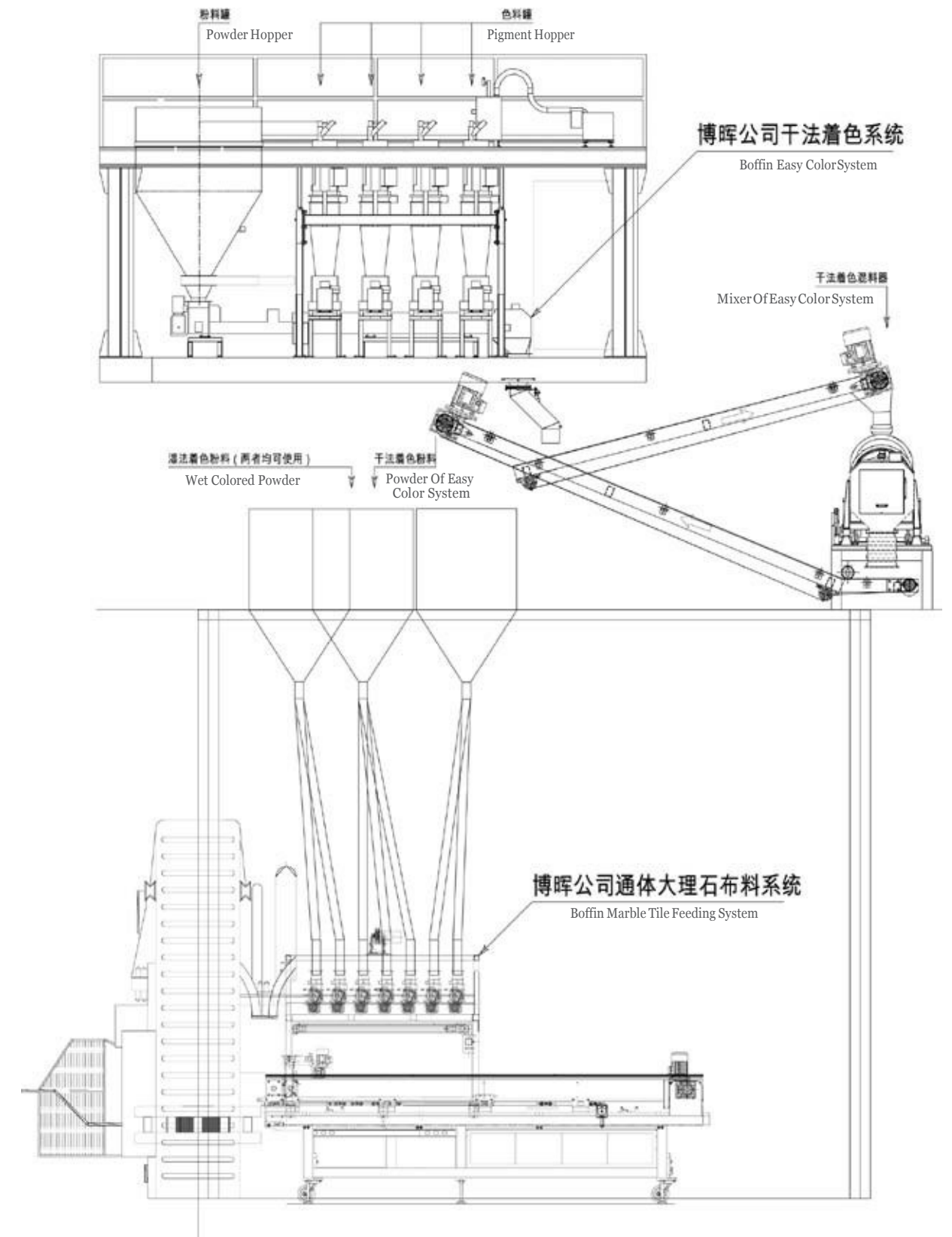
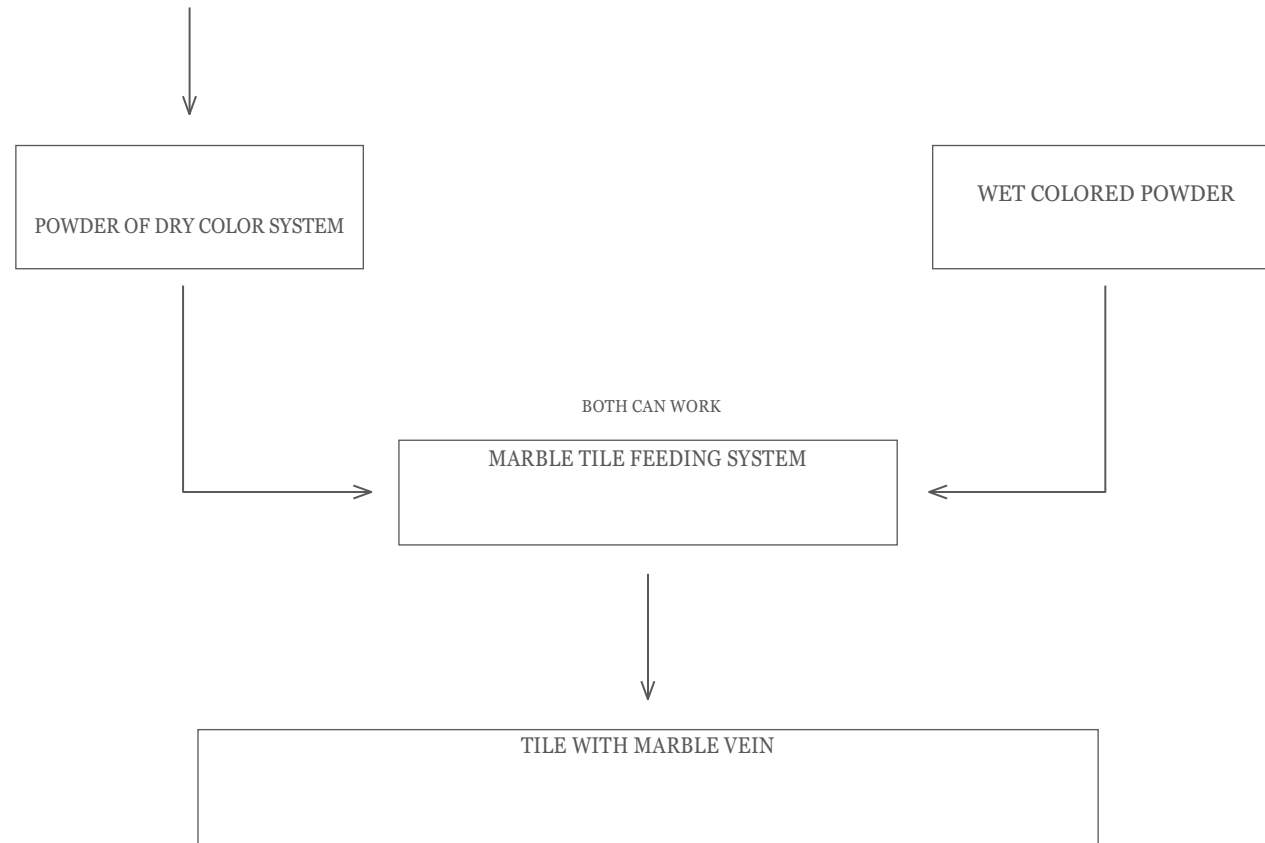



■ GOLD CROWN AUSTRALIA SAND FEEDING SYSTEM



GOLD CROWN AUSTRALIA SAND FEEDING SYSTEM

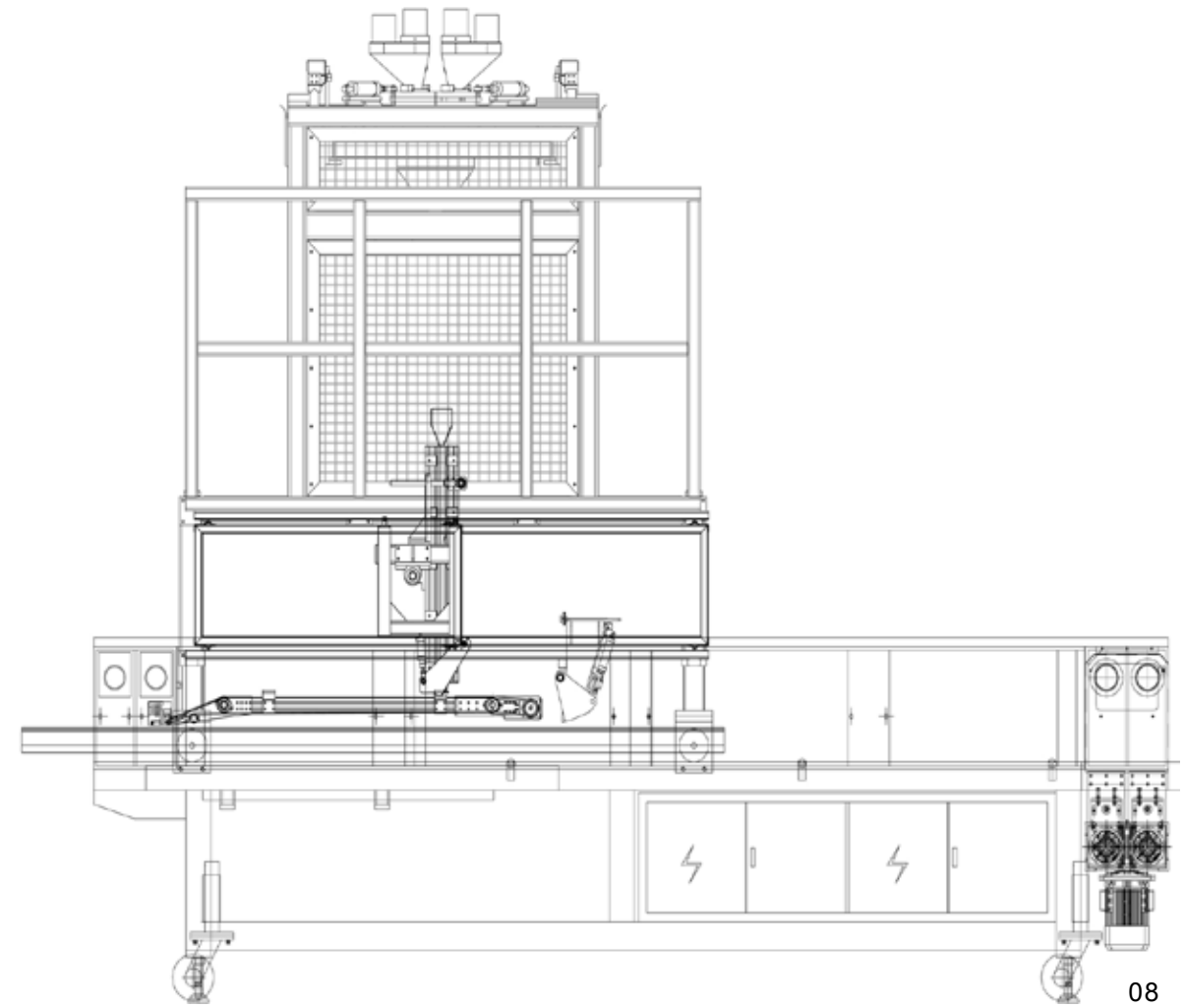

AUSTRALIA SAND STONE



GOLD CROWN FEEDING SYSTEM

GOLDCROWN  
II

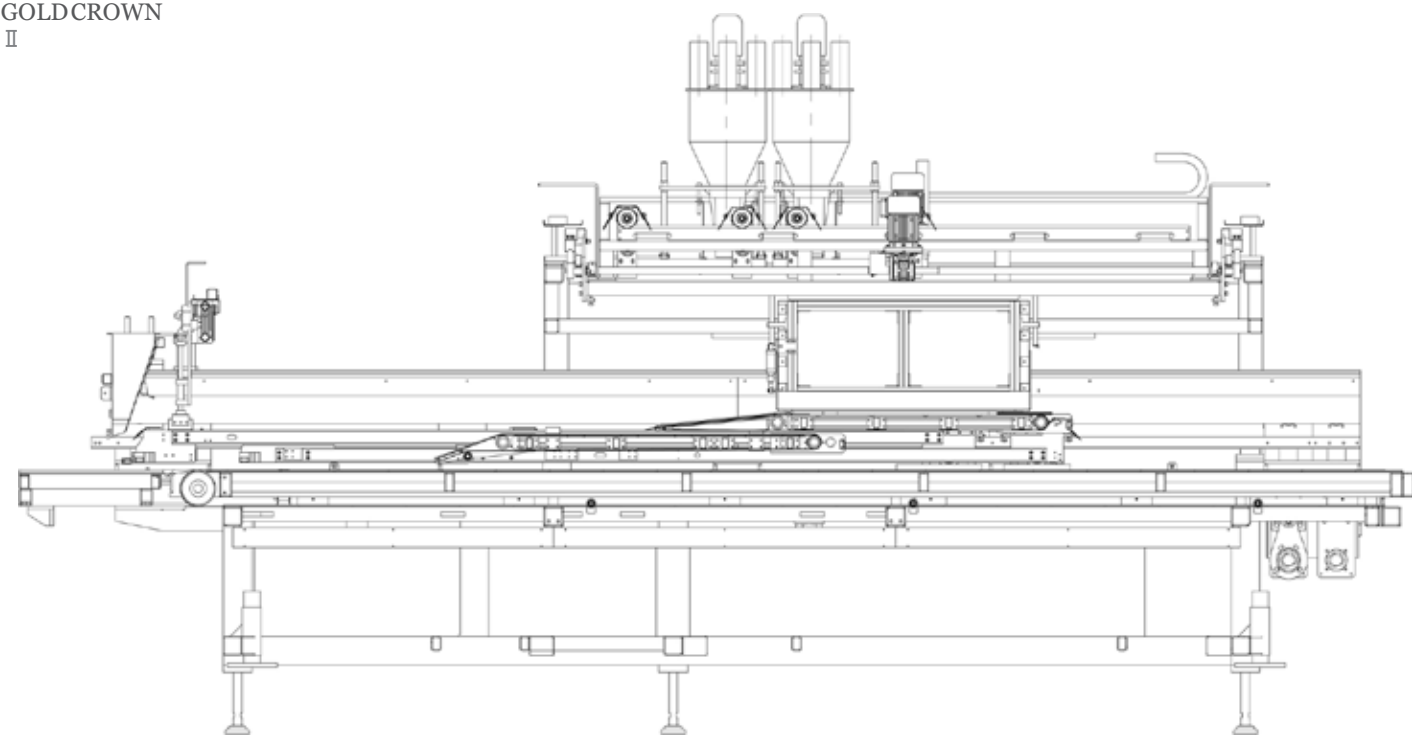

AMAZON

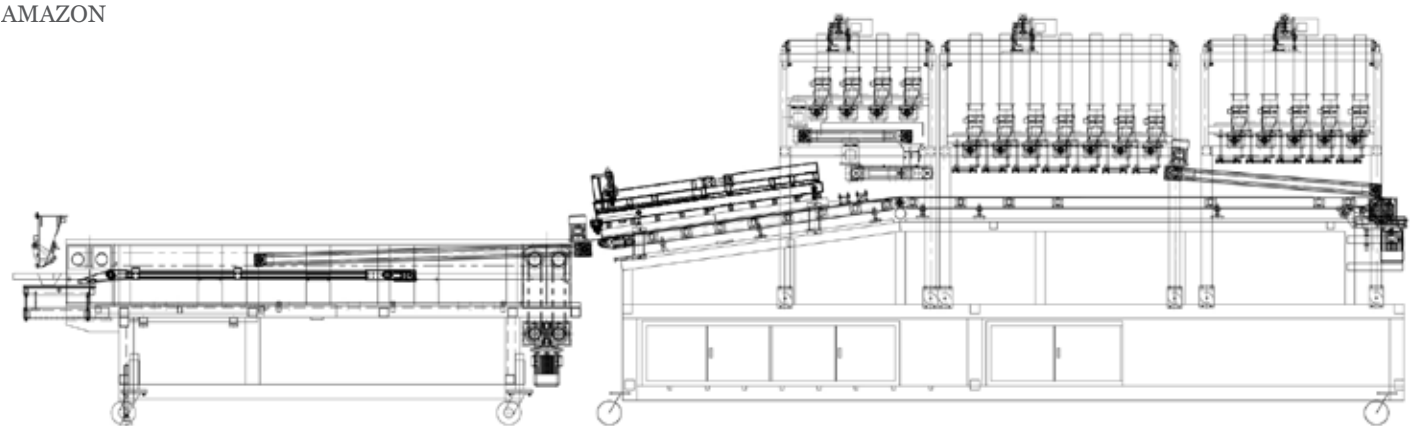

GOLD CROWN FEEDING SYSTEM

ITALY SAND STONE

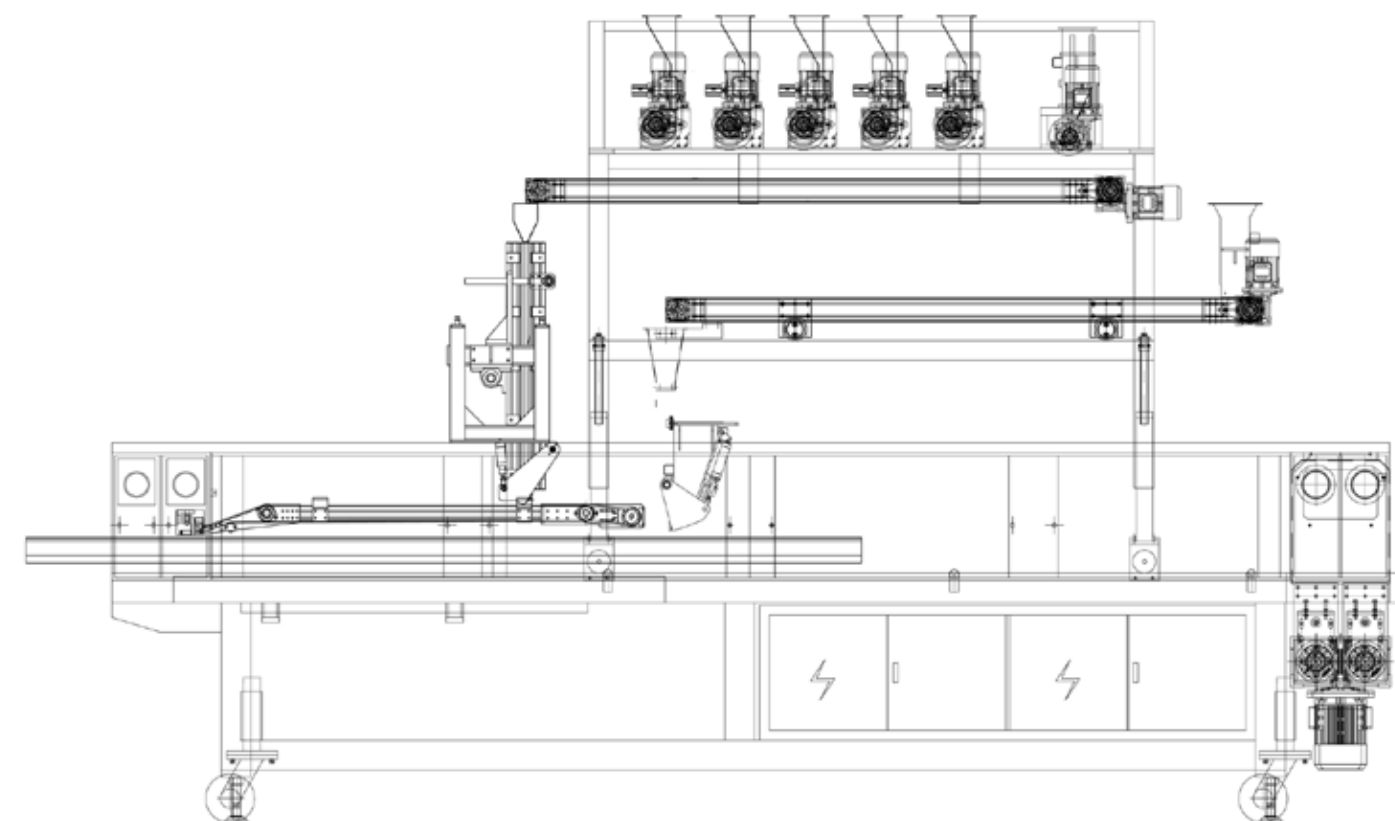





- GOLD CROWN - AMAZON FEEDING SYSTEM

GOLD CROWN - AMAZON FEEDING SYSTEM

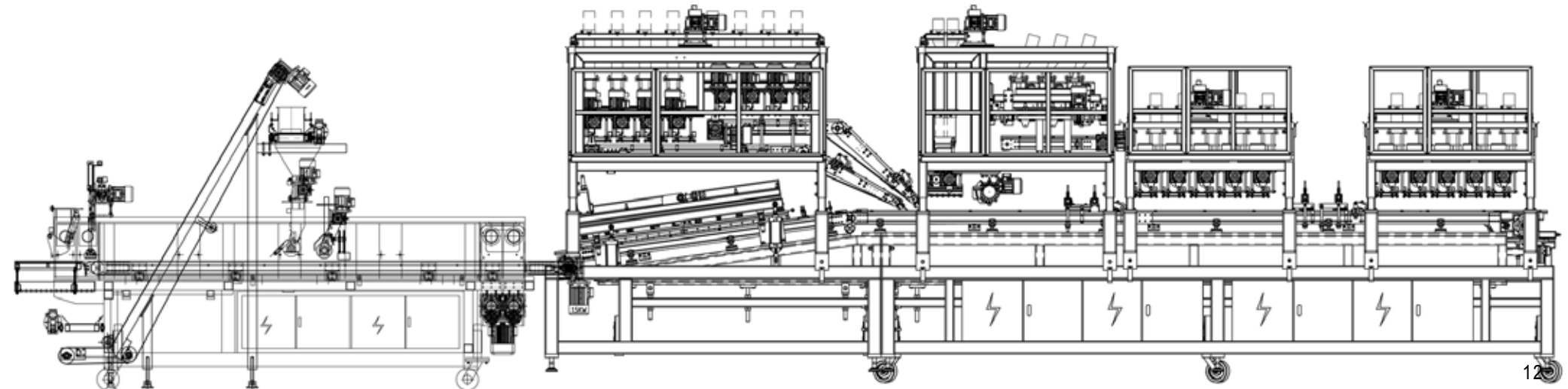





APOLLO OMNI-DIRECTIONAL FEEDING SYSTEM



APOLLO

APOLLO OMNI-DIRECTIONAL FEEDING SYSTEM

APOLLO PLATFORM

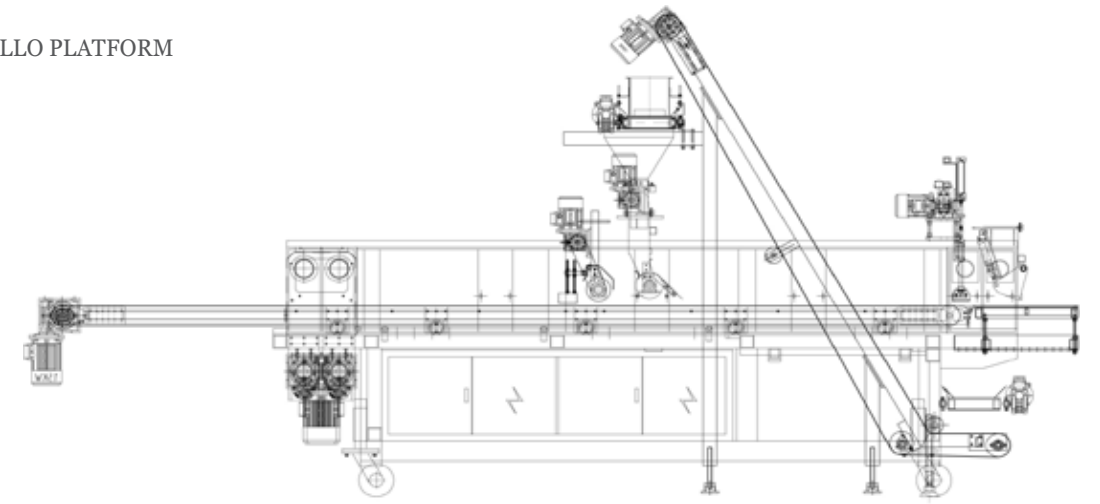

PLATINUM MODULE

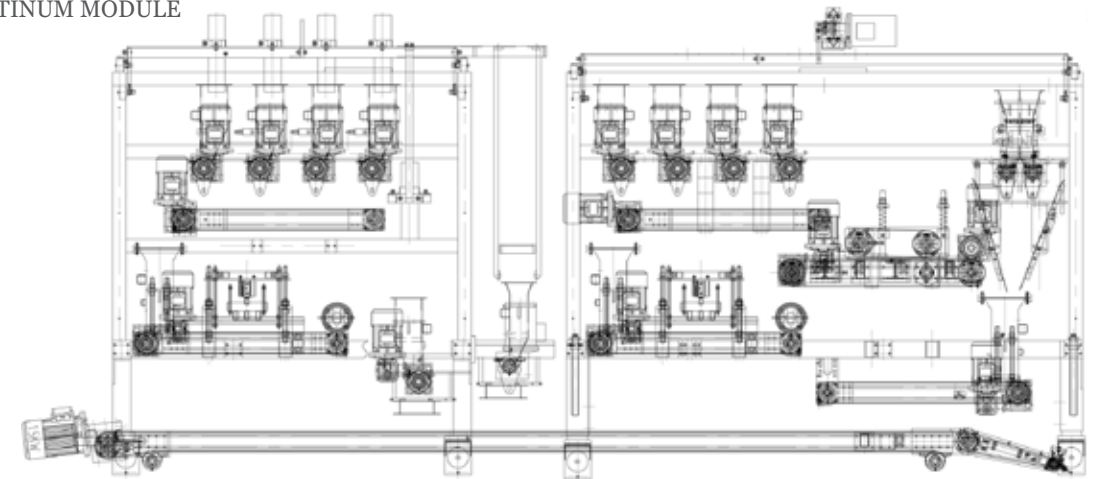

APOLLO MODULE



Apollo Omni-Directional Feeding System

ALMOND FLOWER MODULE

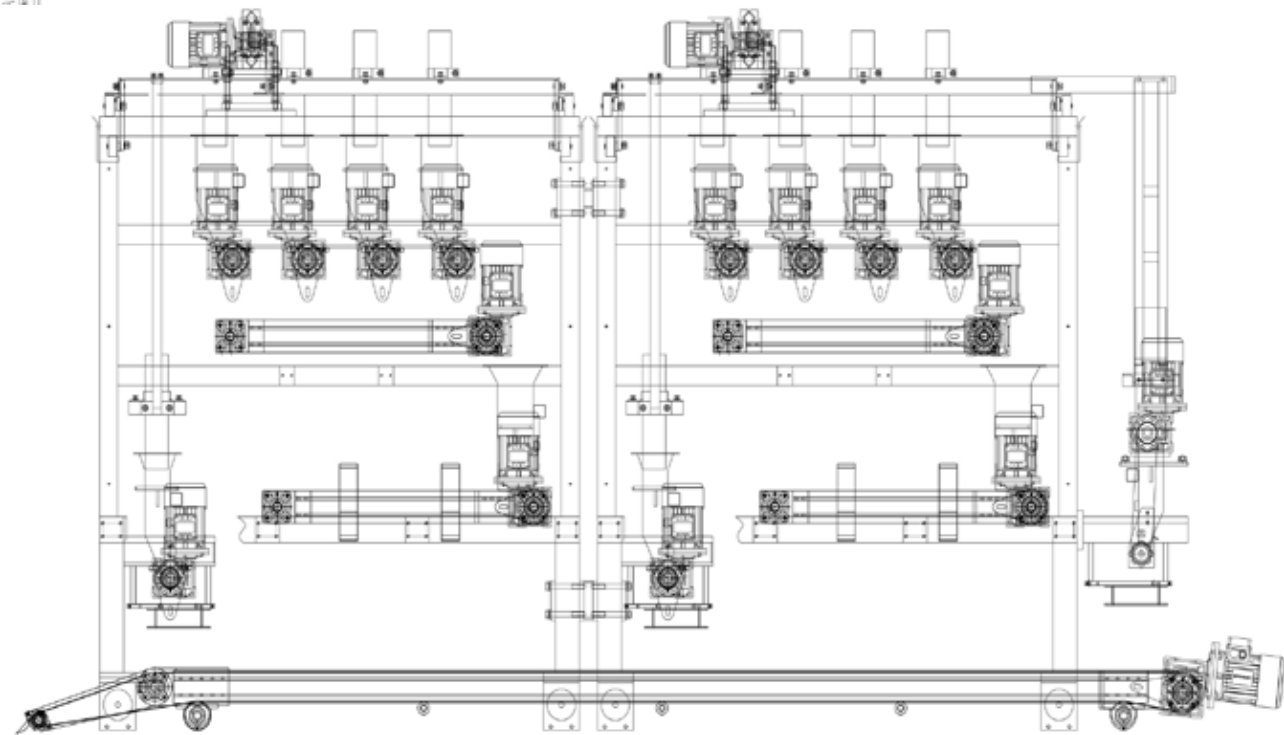

NEW NOBLE MODULE

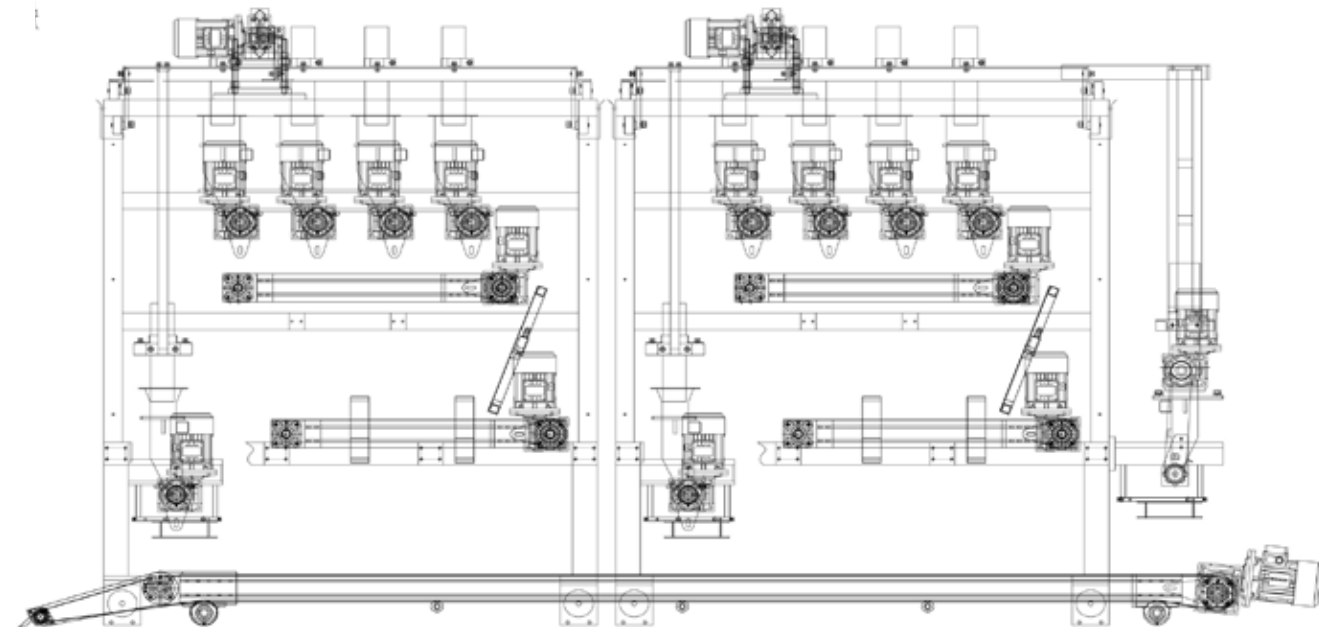

Apollo Omni-Directional Feeding System

RORM MODULE

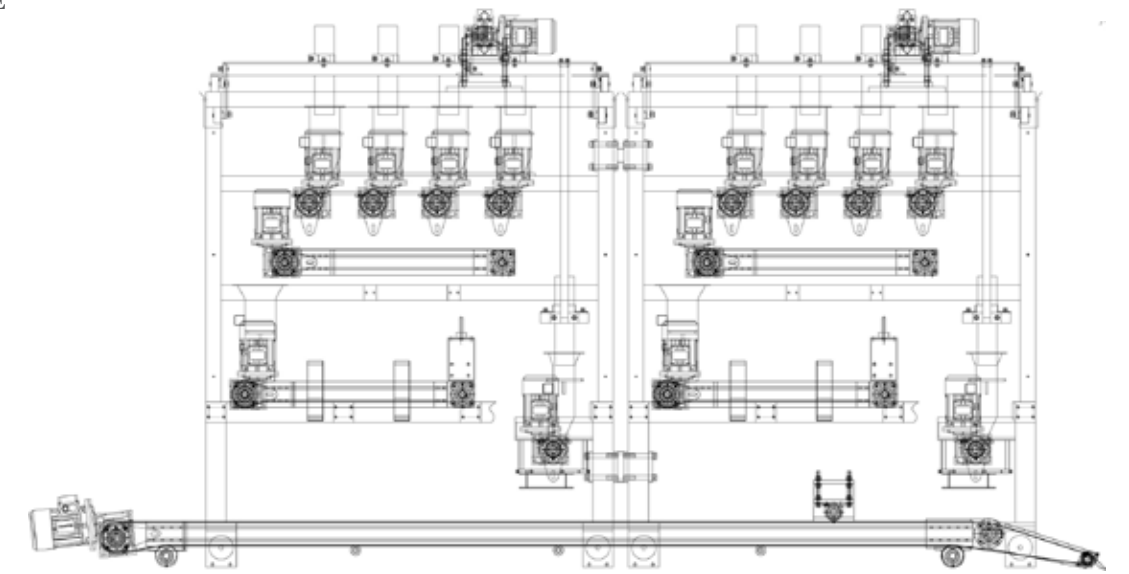

BAROSSA MODULE

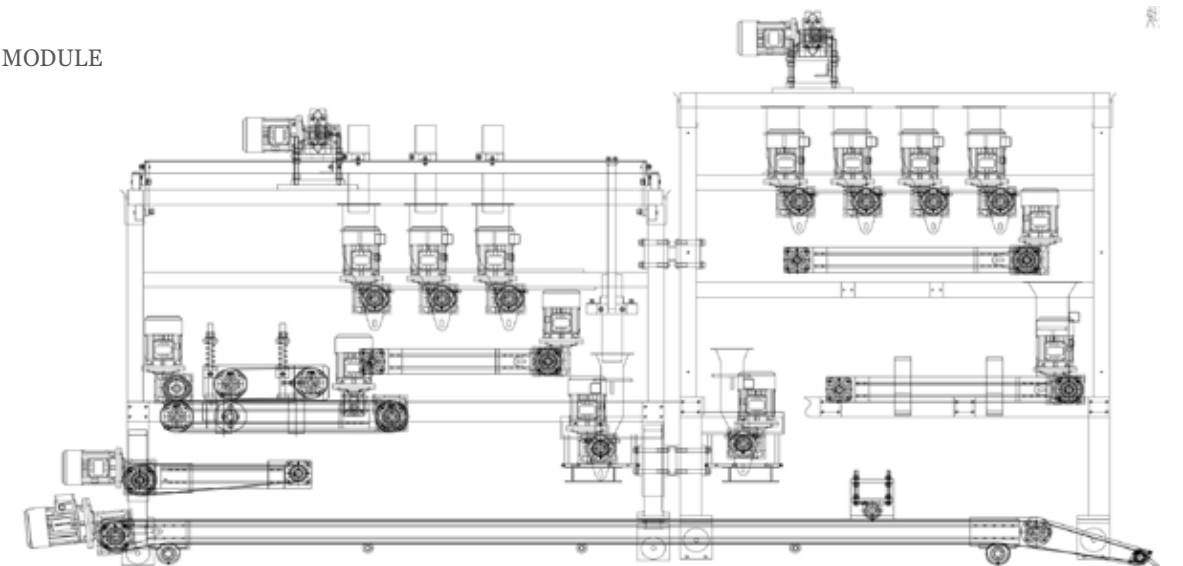

APOLLO II MODULE

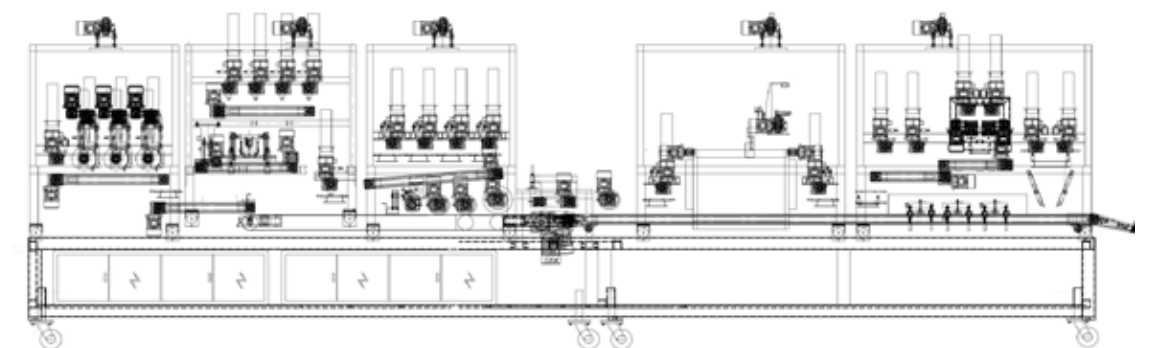





GOLD FLAKE FEEDING SYSTEM

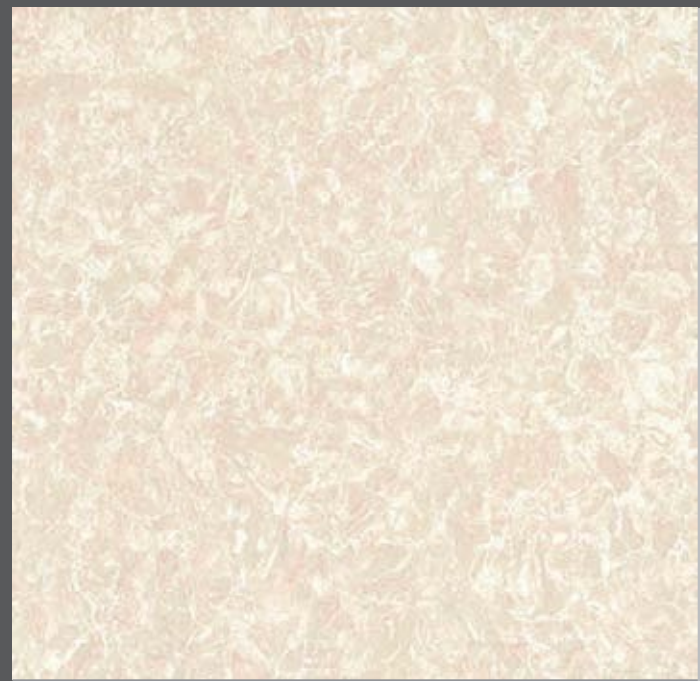

PULATI

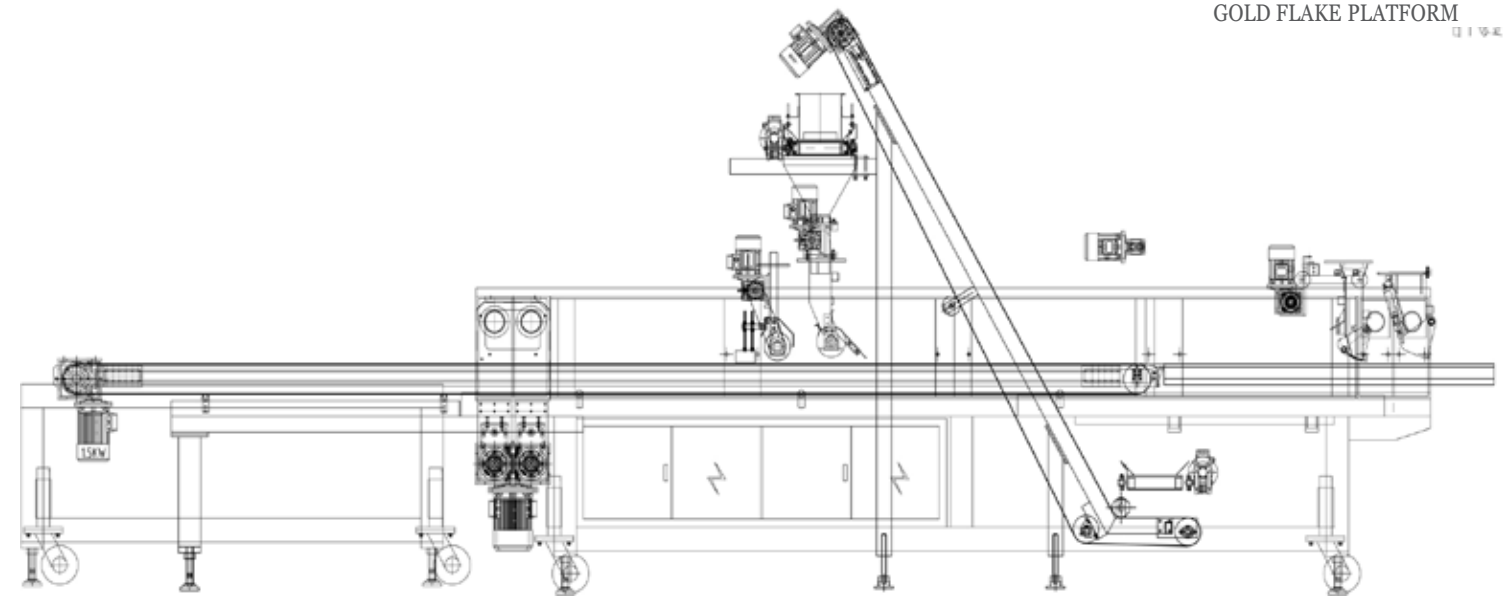

GOLD FLAKE PLATFORM  
图 1 号



GOLD FLAKE FEEDINGSYSTEM

REAL STONE MODULE

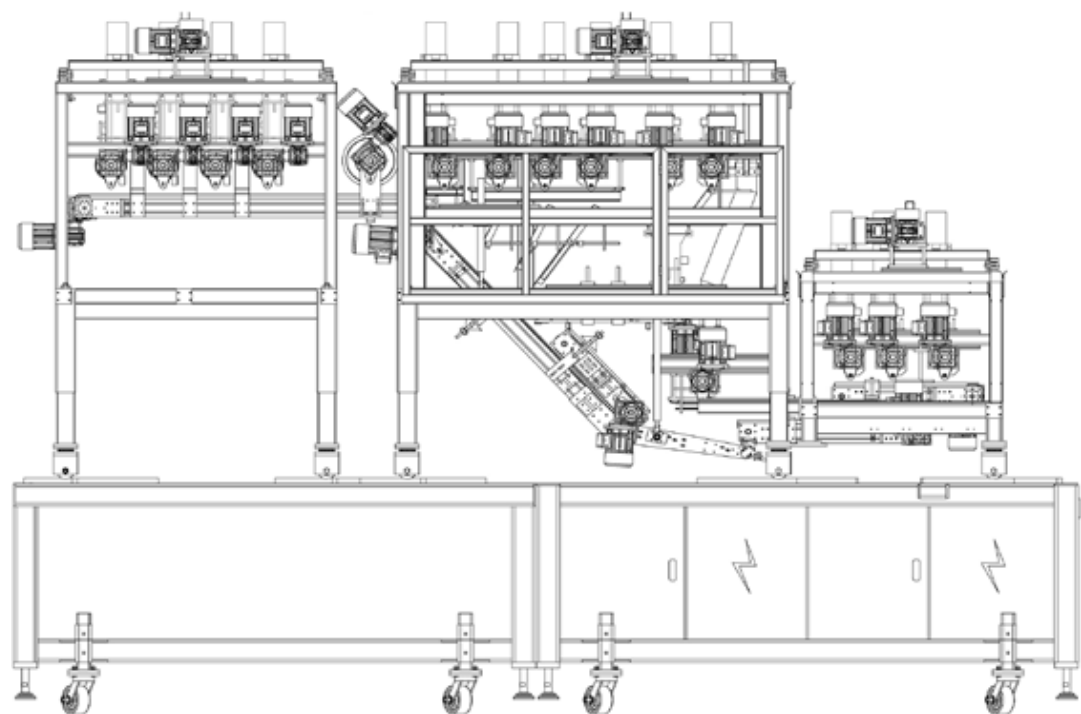

GOLD FLAKE FEEDINGSYSTEM

WOODEN VEIN I MODULE

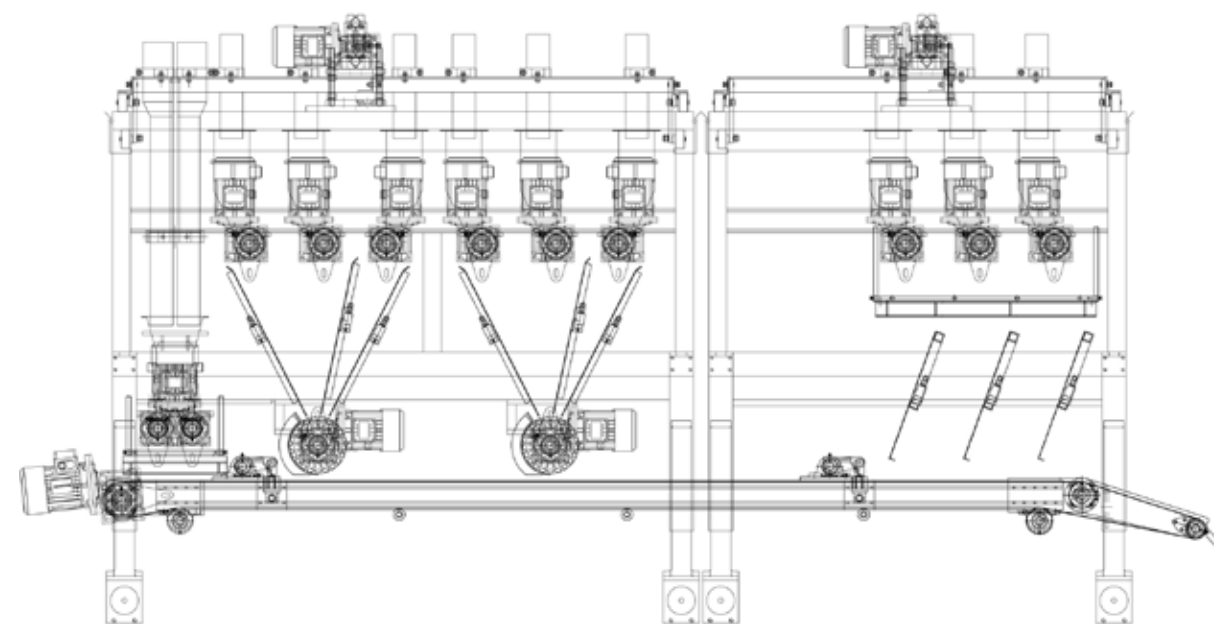

WOODEN VEIN III MODULE

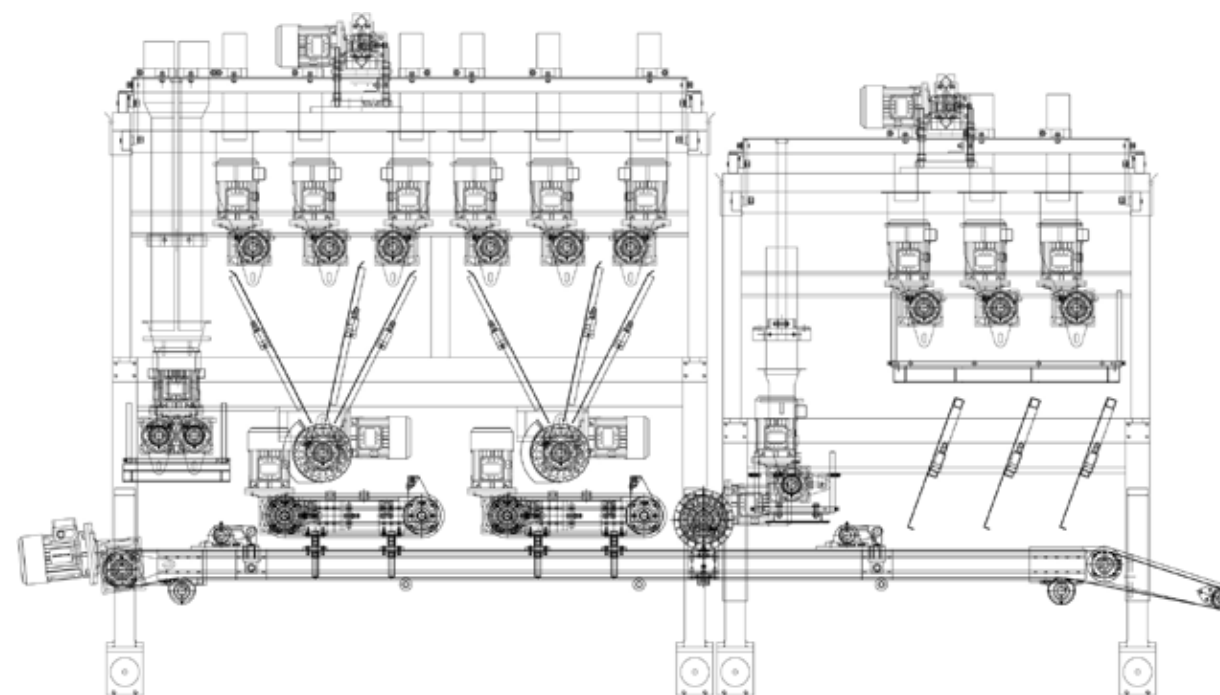

BELT PULATIMODULE

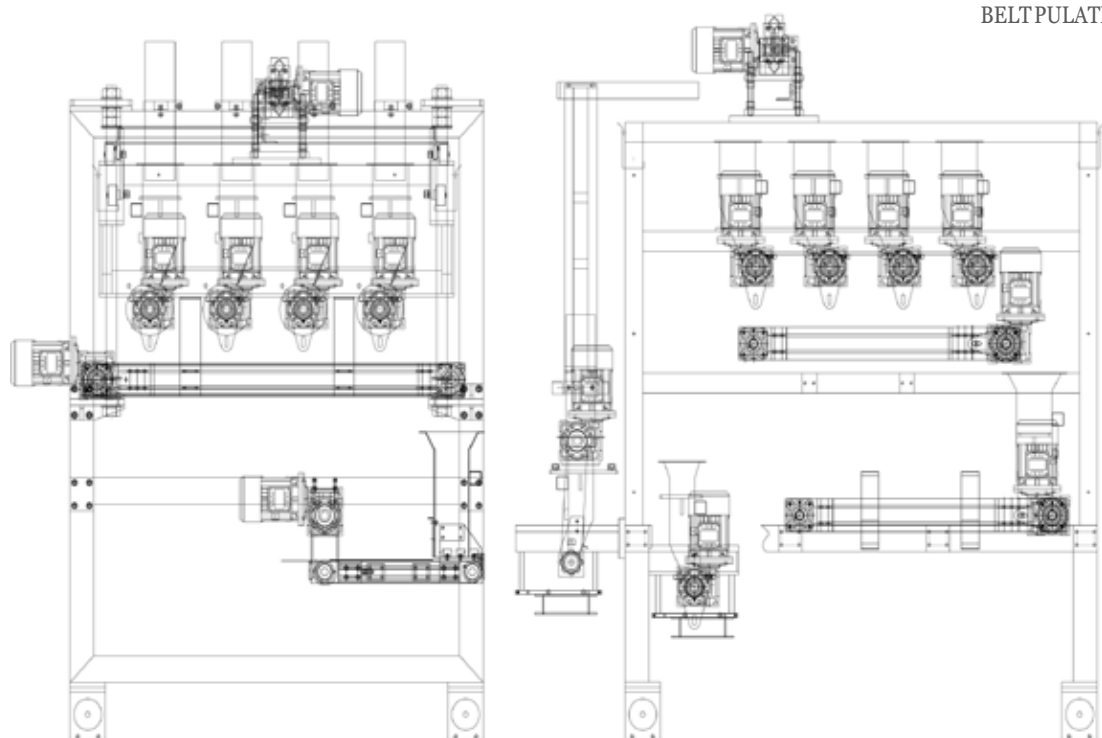



DOUBLE FEEDING SYSTEM  
DOUBLE FEEDING

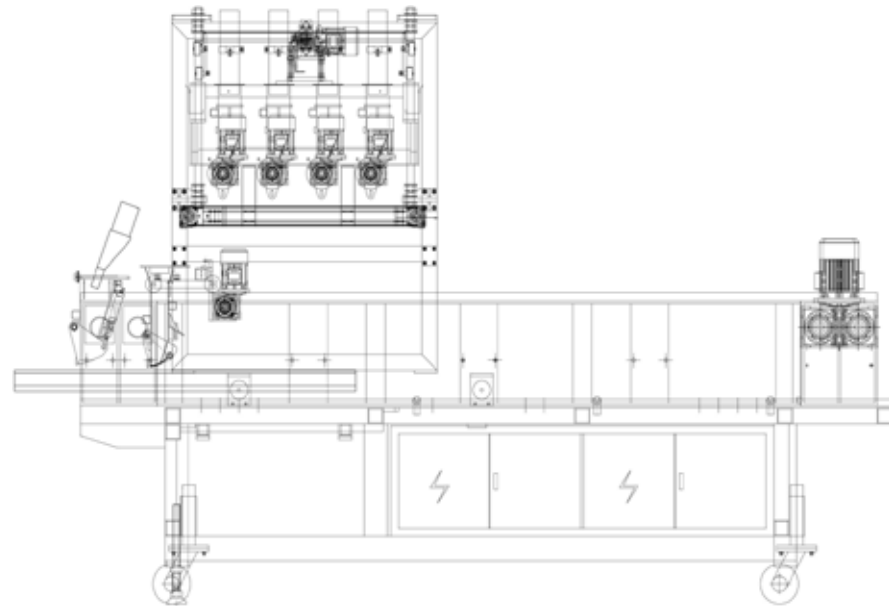

SINGLE DOUBLE FEEDING

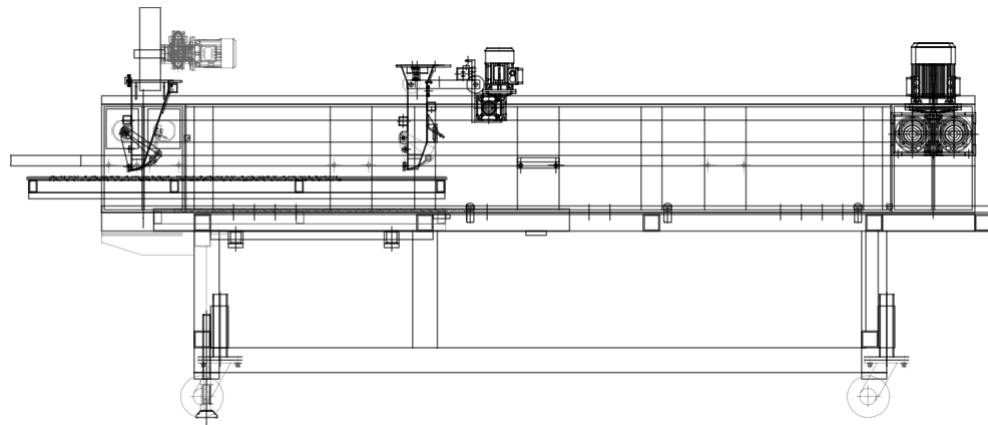

SINGLE FEEDING

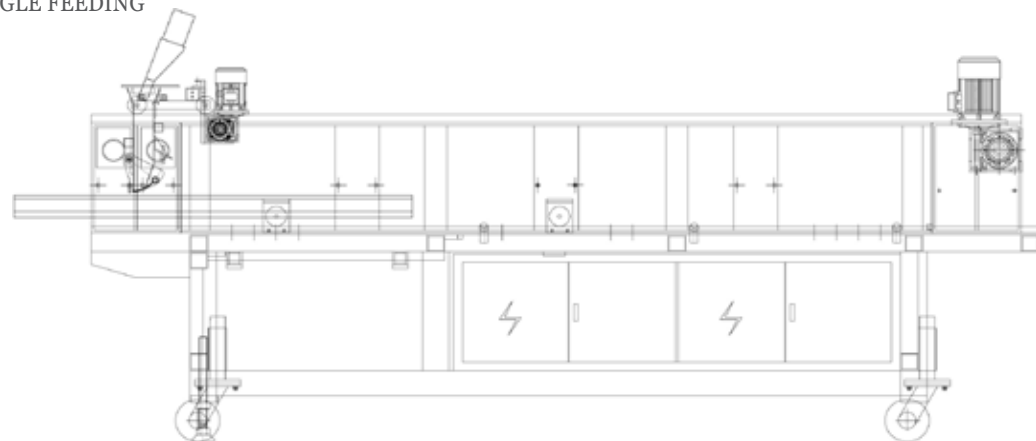

DOUBLE FEEDING SYSTEM

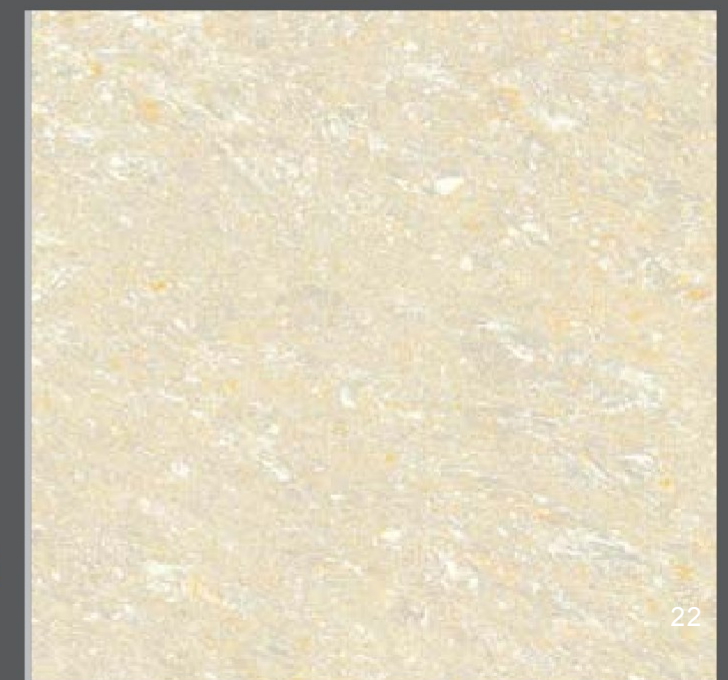

反打聚晶  
REVERSED FEEDING TILE